



Swing Check Valves

Form 12833 – rev 03/14

Product Features

- Gravity operated.
- Sizes: 2.5" – 12" (DN65 - DN300).
- UL Listed and FM Approved.
- 200 psig (14 Barg).
- Designs available: U2120-BB Bronze Disc and Seat Rings; U2122-B1 Rubber Disc Facing and Bronze Seat Ring.
- Cast Iron Valve Body, ASTM A-126 Class B.
- Two-part liquid epoxy coating for superior corrosion resistance.
- Cast Iron Cover has lifting lug.
- Operating parts of bronze and stainless steel, Cover Nuts and Bolts are electro galvanized steel to resist corrosion.
- Internal parts serviceable without removing valve from line.
- Tapping bosses both sides of body for connecting by-pass.
- Drain plug under inlet end for connecting drain valve.
- End connection: Flanged ANSI B16.1 Class 125.

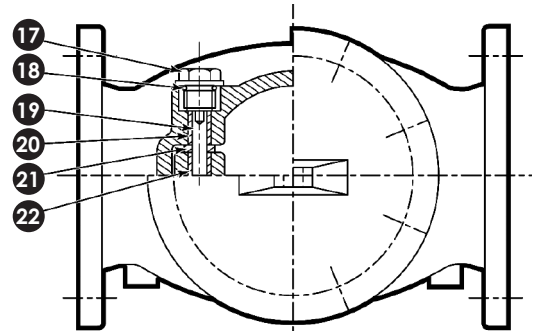
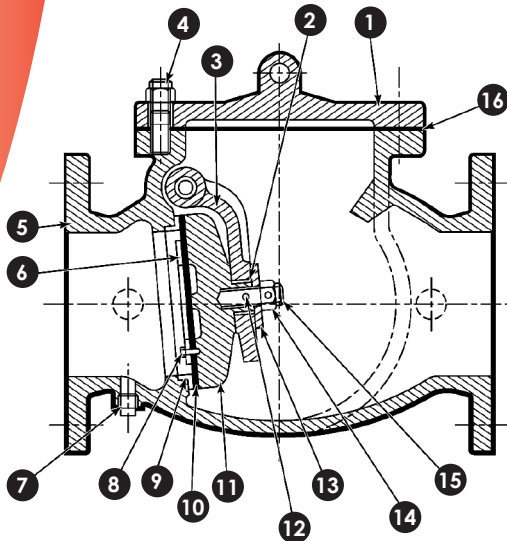
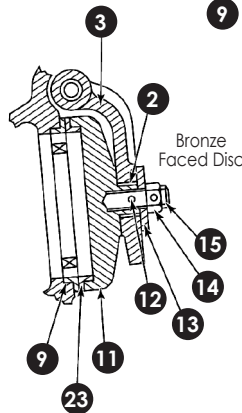
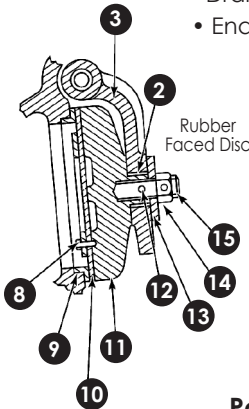
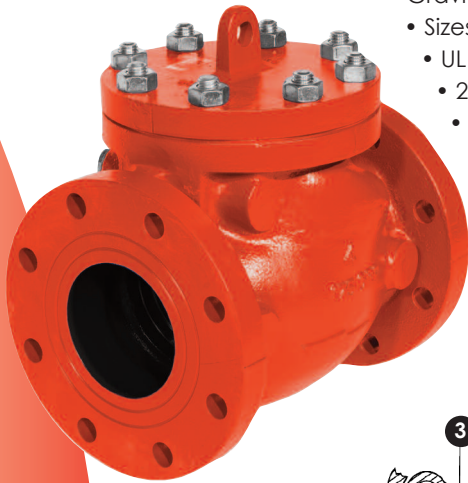

Parts List

ID	PART NAME	MATERIAL & MATERIAL STANDARDS
1	Cover	Cast Iron ASTM 126 Class B
2	Arm Disc Bushing	Bronze ASTM B62
3	Arm	Cast Iron ASTM 126 Class B
4	Cover Stud & Nut	Zinc Coated Steel ASTM A307 Grade B
5	Body	Cast Iron ASTM 126 Class B
6	Seat Holder	Bronze ASTM B62
7	Plug (B)	Malleable Iron ASTM 47
8	Disc Seat Bolt	Stainless Steel ASTM A276 Type 304
9	Body Seat Ring	Bronze ASTM B62
10	Disc Seat Ring	Rubber Buna D2000 BK707
11	Disc	Cast Iron ASTM 126 Class B
12	Pin	Stainless Steel ASTM 276 Type 304
13	Washer	Brass ASTM B21
14	Disc Nut	Brass ASTM B21
15	Disc Stud	Brass ASTM B21
16	Cover Gasket	Rubber Buna D2000 BK 707
17	Plug	Brass ASTM B21
18	O-Ring	Rubber Buna N D2000 BK 707
19	Hinge Pin	Stainless Steel ASTM 276 Type 304
20	Body Bushing	Bronze ASTM B62
21	Spacer	Bronze ASTM B62
22	Arm Bushing	Bronze ASTM B62
23	Disc Seat Ring	Bronze ASTM B62



INTERNATIONAL DIVISION

Swing Check Valve

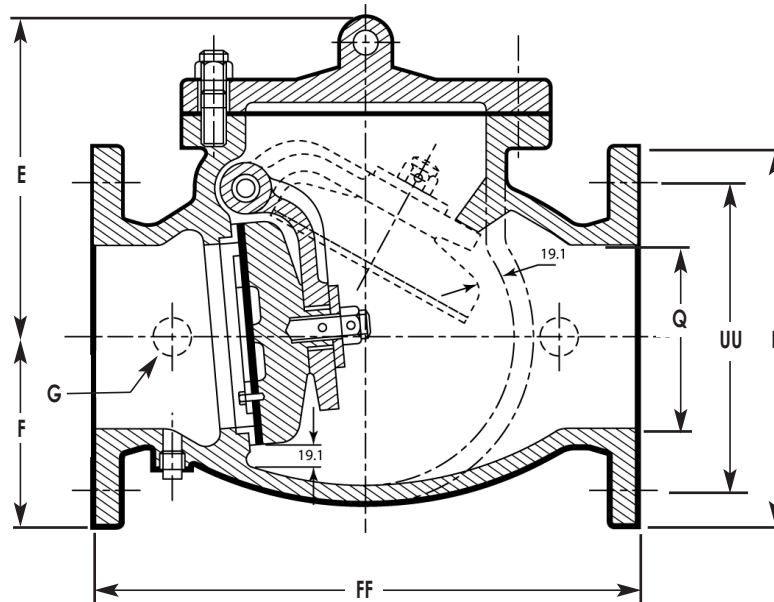

Dimensions – inches (mm)

VALVE SIZE	E	F	FF	G	R	UU	Q
2.5" (DN65)	6.57 (167)	3.50 (89)	8.50 (216)	1.50 (38)	7.01 (178)	5.51 (140)	2.50 (65)
3" (DN80)	7.48 (190)	3.78 (96)	9.50 (241)	1.50 (38)	7.52 (191)	5.98 (152)	3.00 (80)
4" (DN100)	8.31 (211)	4.53 (115)	11.50 (292)	1.50 (38)	9.02 (229)	7.52 (191)	4.00 (100)
6" (DN150)	10.59 (269)	5.51 (140)	14.00 (356)	1.75 (44)	10.98 (279)	9.49 (241)	6.00 (150)
8" (DN200)	12.20 (310)	6.77 (172)	19.50 (495)	1.75 (44)	13.50 (343)	11.77 (299)	8.00 (200)
10" (DN250)	13.86 (352)	7.99 (203)	24.50 (622)	2.00 (53)	15.98 (406)	14.25 (362)	10.00 (250)
12" (DN300)	16.26 (413)	9.53 (242)	27.50 (698)	2.00 (53)	19.02 (483)	17.01 (432)	12.00 (300)

Weight – lb (Kg)

VALVE SIZE	Rubber Disc	Bronze Disc
2.5" (DN65)	59 (26)	59 (26)
3" (DN80)	66 (30)	66 (30)
4" (DN100)	110 (49)	112 (50)
6" (DN150)	198 (89)	196 (88)
8" (DN200)	330 (149)	330 (149)
10" (DN250)	497 (225)	497 (225)
12" (DN300)	693 (314)	702 (318)

Copyright © 2014 Mueller Co., LLC. All Rights Reserved. The trademarks, logos and service marks displayed in this document herein are the property of Mueller Co., LLC, its affiliates or other third parties. These products are intended for use in potable water applications. Please contact your Mueller Sales or Customer Service Representative concerning any other application(s).



INTERNATIONAL DIVISION